

X10 Relay Boards

Low Voltage X10 Relay Control Boards
With 4, 8, or 16 Relays

August 2000

v1.4

©1998-2000 Creative Control Concepts

Disclaimer

- While we have attempted to provide accurate and up-to- date information in this manual, Creative Control Concepts makes no representations or warranties respecting its contents.
- We reserve the right to make periodic changes to the text and to issue new editions of this manual without notification.
- Occasionally in this manual, we refer to other manufacturers' products. Such references do not constitute an endorsement of these products, but are included for the purpose of illustration or clarification. We do not intend such technical information and interface data to supersede information provided by individual manufacturers.
- Devices sold by Creative Control Concepts are covered by the warranty and patent indemnification provisions appearing in its Terms of Sale only. Creative Control Concepts makes no warranty, express, statutory, implied, or by description regarding the information set forth herein or regarding the freedom of the described devices from patent infringement. Creative Control Concepts makes no warranty of merchantability or fitness for any purposes.
- Creative Control Concepts reserves the right to discontinue production and change specifications and prices any time and without notice.
- This product is intended for use in normal commercial applications. Applications requiring extended temperature and unusual environmental requirements, or applications requiring high reliability such as military, medical life support or life-sustaining equipment, are **specifically not recommended**.

Conditions of Sale and Product Warranty

Creative Control Concepts and the Buyer agree to the following terms and conditions of Sale and Purchase:

1. Creative Control Concepts extends the following warranty: a factory manufactured circuit board or assembly carries with it a one-year warranty covering both parts and labor. Any unit which is found to have a defect in materials or workmanship will, at the discretion of Creative Control Concepts, be repaired or replaced.
2. A minimum inspection fee must be prepaid for the repair of units that are no longer under warranty. Call Creative Control Concepts for a current list of fees.
3. Creative Control Concepts will not be responsible for the repair or replacement of any unit damaged by user modification, negligence, abuse and mishandling, or improper installation.
4. Creative Control Concepts is not responsible to the Buyer for any loss or claim of special or consequential damages.
5. All units returned for repair must first receive prior authorization from Creative Control Concepts. A return authorization number may be obtained by phone, email, or letter. Please retain a record of the return authorization number since most subsequent correspondence will refer to this authorization. Under no circumstances should any product be returned to Creative Control Concepts without such authorization. Creative Control Concepts assumes no responsibility for returns unaccompanied by an authorization number. All returns must be shipped prepaid and ought to be insured. Creative Control Concepts is not responsible for losses or damage during shipment. Repaired units will be returned with postage and insurance paid.
6. Creative Control Concepts reserves the right to alter any feature or specification at any time. This right extends to fees, charges, and any other conditions or warranties contained herein.

X10 Relay Board Overview

The CCC X10 Relay Boards give you complete control over low voltage devices in your home. Use X10 Relay Boards to control things like sprinklers, electric door strikes, thermostats, furnaces, HVAC dampers, outdoor landscape lights, security strobes, etc.

CCC X10 Relay boards come with 4, 8, or 16 relays. The boards can be set to respond to any of the normal X10 house codes. Boards with less than 16 relays can be set to respond to different sets of unit codes.

CCC X10 Relay boards are very flexible. You can configure them to latch relays when an ON command is received so it requires an OFF command to turn it off. You can also configure a board in momentary mode so relays are pulsed for 1 second when an ON is received. If you hold down the ON button on an X10 controller, the relay will stay on and then turn off 1 second after you release the button. The X10 Relay Boards also support group X-10 commands that some Home Automation controllers offer. If you want to turn on 4 relays, instead of sending 4 X-10 command pairs, you can send A1, A2, A3, A4 followed by a single A ON and all four relays will turn on. This works in momentary mode as well.

Each relay is a dual-pole, dual throw type. This allows you to control two separate circuits with one relay. You also can wire circuits Normally Open or Normally Closed. Each pole can handle 2 Amps of current @ 30VDC. Use both contacts in parallel and you can handle 4 Amps at up to 30VDC.

While these relays can control 120VAC at ~0.5 Amp, these boards are **NOT** intended to do so. They have no fuses and the surge currents during device start may burn out the relays. If you choose to switch 120VAC, proceed at your own risk. However, you are more than welcome to use this board to control larger relays intended for 120VAC switching. We recommend using DIN rail mounted sockets and relays with a minimum of 10A current capacity. The UCN5841 can sink 500mA per relay coil. If you drive larger external relays, a chip heatsink is recommended for the UCN5841. Contact Creative Control Concepts to get one.

The CCC X10 Relay Boards are a great addition to any Home Automation system with X10 capability.

X10 Relay Construction

If you purchased a kit from Creative Control Concepts, read this section for instructions on building your X10 Relay Board. If you purchased an assembled board, skip to Chapter 3.

Make sure all the necessary parts are in the parts bag using the part lists below. If a part is missing, contact us at support@cc-concepts.com for a replacement.

X10 Relay Part Lists

4-Relay X10 Board

Qty	Part	Board Ref
1	4-Relay Circuit Board	NA
1	4-Relay Processor Chip	U1
1	UCN5841 Relay Driver IC	U2
2	18-Pin IC Sockets	U1, U2
1	78L05 Power IC	U3
1	4MHz Crystal w/Insulator	X1
1	BCD Hex Rotary Switch	SW1
4	12VDC Relays	Y1-Y4
4	Yellow LEDs	D1-D4
1	Green LED	D5
3	10K ¼W Resistors (Brown-Black-Orange)	R1-R3*
5	820Ω ¼W Resistors (Grey-Red-Brown)	R3-R6, R8*
12	2-position Terminal Blocks	NA
1	2.1mm Power Jack	J1
1	RJ-11 Modular Jack	J2
1	2x3 IDC Header	J3
2	20pF Capacitors	C1-C2
1	100uF 25V Capacitor	C3
2	0.1uF Capacitors	C4-C5
3	Shorting Blocks	NA
1	12V 200mA Power Supply	NA

8-Relay X10 Board

Qty	Part	Board Ref
1	8-Relay Circuit Board	NA
1	8-Relay Processor Chip	U1
1	UCN5841 Relay Driver IC	U2
2	18-Pin IC Sockets	U1, U2
1	78L05 Power IC	U3
1	4MHz Crystal w/Insulator	X1
1	BCD Hex Rotary Switch	SW1
8	12VDC Relays	Y1-Y8
8	Yellow LEDs	D1-D4, D6-D9
1	Green LED	D5
3	10K ¼W Resistors (Brown-Black-Orange)	R1-R3
9	820Ω ¼W Resistors (Grey-Red-Brown)	R4-R12
24	2-position Terminal Blocks	NA
1	2.1mm Power Jack	J1
1	RJ-11 Modular Jack	J2
1	2x3 IDC Header	J3
2	20pF Capacitors	C1-C2
1	100uF 25V Capacitor	C3
2	0.1uF Capacitors	C4-C5
3	Shorting Blocks	NA
1	12V 500mA Power Supply	NA

* There is an error on the 4-Relay Circuit Board where two resistors are named R3. However, each one also has the resistor value printed near it. Ensure the right resistor is inserted in the right place.

** **NOTE** ** All boards require a TW-523 2-way X10 Interface and a connecting cable. These are available from Creative Control Concepts at <http://www.cc-concepts.com/>

X10 Relay Part Lists (Continued)

16-Relay X10 Board

Qty	Part	Board Ref
2	16-Relay Circuit Boards	NA
1	16-Relay Processor Chip	U1
2	UCN5841 Relay Driver IC	U2
3	18-Pin IC Sockets	U1, U2
2	78L05 Power IC	U3
1	4MHz Crystal	X1
1	BCD Hex Rotary Switch	SW1
16	12VDC Relays	Y1-Y8*
16	Yellow LEDs	D1-D4, D6-D9*
2	Green LED	D5*
2	10K ¼W Resistors (Brown-Black-Orange)	R1-R3*
18	820Ω ¼W Resistors (Grey-Red-Brown)	R4-R12*
48	2-position Terminal Blocks	NA
1	2.1mm Power Jack	J1
1	RJ-11 Modular Jack	J2
1	2x2 IDC Header	J3
2	20pF Capacitors	C1-C2
2	100uF 25V Capacitor	C3
4	0.1uF Capacitors	C4-C5
4	Shorting Blocks	NA
2	3-Pin Header	J4
2	2x7 IDC Header	J5
1	1ft Expansion Cable	NA
1	12V 1250mA Power Supply	NA

**** NOTE **** All boards require a TW-523 2-way X10 Interface and a connecting cable. These are available from Creative Control Concepts at <http://www.cc-concepts.com/>

Constructing your X10 Relay Board is very easy. Anyone with decent soldering skills can do it. Be sure to read these instructions carefully before soldering anything. Desoldering a double-sided board can be difficult so make sure before you solder! Pictures are available on our website if you want a picture representation. Goto <http://www.cc-concepts.com/>

These instructions are broken up into three sections, one section for each type of board.

4-Relay Construction Steps

- 1) Your circuit board has one side with white markings that indicate where parts should go. It is labeled "Component Side" which is the side all components should be installed on.
- 2) Check that all the parts are in the parts bag according to the list at the beginning of Chapter 2.
- 3) Install the resistors R1-R8. Note that a mistake in the solder silkscreen resulted in two R3's. The R3 next to R1 and R2 should be 10K and the R3 below the Yellow LED should be 820 Ohms.
- 4) Install capacitors C1 & C2 & the crystal X1 (Metal can with 4.0000 on top)
- 5) Install the IC Sockets for U1 & U2. Pay attention to line up the notch in the socket with the notch on the silkscreen.
- 6) Install the Rotary Switch SW1. The corner with the white dot should point towards the angled corner on the silkscreen.
- 7) Install capacitors C4 & C5. If the capacitor is blue and has a + sign on it, ensure the + symbol on the capacitor aligns with the + symbol on the board. If they are tan they can be inserted either way.
- 8) Install U3 and ensure the flat side aligns with the silkscreen symbol.
- 9) Install the 2x3 Header (J3). Install J1. It will require substantial solder to fill the large holes.
- 10) Install the LEDs. The Yellow LEDs should be installed as D1-D4. The Green LED is D5. Ensure that the flat edge on the LEDs aligns with the silkscreen.
- 11) Assemble the blue terminal blocks together using the dovetail rails on their sides. Insert the assembly with the wire holes pointing away from the board and solder it into place. Use masking tape to hold it in place during soldering.
- 12) Insert J2 into the appropriate holes and firmly press down to seat the plastic posts. Then solder the pins in place.
- 13) If you wish, wash the flux off using an appropriate flux remover and allow the board to dry overnight.
- 14) Insert the processor chip into socket U1 and the UCN5841 Relay Driver into U2.

8-Relay Construction Steps

- 1) Your circuit board has one side with white markings that indicate where parts should go. It is labeled "Component Side" which is the side all components should be installed on.
- 2) Check that all the parts are in the parts bag according to the list at the beginning of Chapter 2.
- 3) Install the resistors R1-R12. Resistors can be installed in either direction.
- 4) Install capacitors C1 & C2 & the crystal X1 (Metal can with 4.0000 on top)
- 5) Install the IC Sockets for U1 & U2. Pay attention to line up the notch in the socket with the notch on the silkscreen.
- 6) Install the Rotary Switch SW1. The corner with the white dot should point towards the angled corner on the silkscreen.
- 7) Install capacitors C4 & C5. If the capacitor is blue and has a + sign on it, ensure the + symbol on the capacitor aligns with the + symbol on the board. If they are tan they can be inserted either way.
- 8) Install U3 and ensure the flat side aligns with the silkscreen symbol. Install C3 ensuring the long lead is inserted in the pad labeled with a +.
- 9) Install the 2x3 Header (J3). Install the power jack J1. It will require substantial solder to fill the large holes.
- 10) Install the LEDs. The Yellow LEDs should be installed as D1-D4 & D6-D9. The Green LED is D5. Ensure that the flat edge on the LEDs aligns with the silkscreen.
- 11) Split the terminal blocks into two groups of 12. Assemble the 12 blue terminal blocks together using the dovetail rails on their sides. Insert the assemblies with the wire holes pointing away from the board and solder them into place. Use masking tape to hold them in place during soldering.
- 12) Insert J2 into the appropriate holes and firmly press down to seat the plastic posts. Then solder the pins in place.
- 13) Install the relays Y1-Y8.
- 14) Note that J4 and J5 are not used in the 8-Relay X10 Board.
- 15) If you wish, wash the flux off using an appropriate flux remover and allow the board to dry overnight.
- 16) Insert the processor chip into socket U1 and the UCN5841 Relay Driver into U2.

16-Relay Construction Steps

- 1) Check that all the parts are in the parts bag according to the list at the beginning of Chapter 2.
- 2) The 16-Relay X10 Board is really two 8-Relay boards connected together by a ribbon cable. Take one board and construct it according to the directions for an 8-Relay X10 board. Note that J3 is installed under "M F" on the 1st board. Slot U is left empty and R3 does not get installed.
- 3) Install the 3-pin header (J4) and one 2x7 header (J5) on the 1st board you constructed above.
- 4) Set aside the first circuit board and begin construction of the second board.
- 5) Install the resistors R4-R12. Resistors can be installed in either direction.
- 6) Install the IC Socket for U2. Pay attention to line up the notch in the socket with the notch on the silkscreen. U1 is not used on the second board.
- 7) Install capacitors C4 & C5. If the capacitor is blue and has a + sign on it, ensure the + symbol on the capacitors aligns with the + symbol on the board. If they are tan they can be inserted either way.
- 8) Install C3 and U3 (78L05) the same way they were installed on the first board. Ensure C3 is aligned with the proper polarity (- symbol is on side opposite + sign on circuit board)
- 9) Install the LEDs. The Yellow LEDs should be installed as D1-D4 & D6-D9. The Green LED is D5. Ensure that the flat edge on the LEDs aligns with the silkscreen.
- 10) Split the terminal blocks into two groups of 12. Assemble the 12 blue terminal blocks together using the dovetail rails on their sides. Insert the assemblies with the wire holes pointing away from the board and solder them into place. Use masking tape to hold them in place during soldering.
- 11) Install the 3-pin header (J4) and the 2x7 header (J5) on the board you constructed above.
- 12) Install the relays Y1-Y8 just like you did on the 1st board.
- 13) The following parts are not used on the second board: J1-J3, C1-C2, X1, SW1, U1, R1-R3
- 14) If you wish, wash the flux off each board using an appropriate flux remover and allow the board to dry.
- 15) Insert ICs U1 & U2 into the first board you built and insert U2 into the 2nd board you built. Be sure to align the notches in the socket & the chip.
- 16) Connect the boards together using the included ribbon cable. Ensure the Pin 1 mark on the ribbon cable connector aligns with the "1" on the circuit board. The ribbon cable marks the Pin 1 side of the cable with a red stripe.
- 17) Install a shorting block on J4 of each board. On the board WITH processor U1, install it in the M (master) position. On the 2nd board, install the jumper in the S (slave) position.

X10 Relay Installation

Installing an X10 Relay Board from CCC is very simple. However, the intended mounting location must meet a few criteria. The board must be located near an outlet so the power supply and TW523 X10 interface can be connected to your home's electrical wiring.

Mount the X10 Relay board where it will not be subject to damage or excessive moisture. Ideally, the X10 Relay Board should be mounted inside some type of enclosure. While not required, it is recommended an enclosure with vents be used since the relays can get warm during operation. The small size of these boards allows them to be mounted in many larger electrical enclosures. Visit your local home improvement store to locate suitable enclosures and mounting hardware. 4-40 size screws should be used for mounting the circuit board. Make sure your enclosure has knockouts for running wires inside.

Once you have mounted the board in a suitable location, it must be connected. Plug the power supply cable into the round power jack on the X10 Board. Plug the power supply into a nearby outlet. **If you do not use the power supply provided by CCC, make sure the output of the supply is < 16VDC, otherwise the LED resistors can overheat.** Most wall wart power supplies marked 12VDC will actually put out 15-17 volts unless they say "regulated". Note that during normal operation, the five 820 Ohm resistors will get warm.

Now connect the TW-523 interface into another nearby outlet. Use the supplied interface cable to connect the TW-523 to the X10 Relay board's TW-523 connector. The X10 Relay Board is now ready for use!

Before you connect any devices to your X10 Relay Board, see if it will respond to your X10 transmitters. Disconnect the power supply. Set the board's house code to a house code you can control with your X10 transmitters. Use the small hex rotary switch with the numbers 0-9 and the letters A-F. 0 is House Code A, 1 is B, 2 is C and so on.

Once you have set the house code, ensure all shorting jumpers are removed. Reconnect the power supply to the board – this will load the current settings of the rotary switch and jumpers. Now try sending an ON command to Unit Code 1. Relay #1 should click and the status LED should turn on. Now try sending an OFF command to Unit Code 1. The relay should click and the status LED should turn off. Your board is now ready for use!

Now you should connect your low voltage devices to your X10 Relay board. Each relay has two sets of switching contacts labeled A and B on the circuit board. Each set has 3 connections: COM (Common), NC (Normally Closed), and NO (Normally Open). The COM connection switches between the NO and NC contacts. When the relay is on, the

COM and NO contacts are connected. When a relay is off, the COM and NC contacts are connected.

Most applications will use the NO contacts. Though it does not matter, power is usually connected to the COM connection and the load is connected to the NO or NC connection. However, a relay is just a mechanical switch so there are no polarity requirements.

It is recommended that any devices you control with this relay board be protected by some type of fuse. If the target device does not have a fuse for its power source, install a fuse inline that is rated at or below the relay ratings (2.5A @ 24VDC, 0.5A @ 120V). Check your actual relays for exact ratings.

Before you use your board for the first time, read the next Chapter on configuration to ensure your jumpers are properly set.

X10 Relay Operation

Before you start using your X10 Relay Board, you must configure it. The boards are configured via the 2x3 IDC Header on the left side of the processor and the hex rotary switch on the right.

Just like any other X10 device, you must select a house code for your X10 Relay Board. The House Code is set using the hex rotary switch. You will notice the switch does not have the normal X10 letters. However, it is a simple relationship. 0 is House Code A, 1 is House Code B, and so on. Thus, A is really J and F is P.

Once you have selected the house code, you need to select a set of Unit Codes for your board if you do not have a 16-Relay board. The relays do not always have to be associated with Unit Codes 1-X.

4-Relay boards can be set to Unit Codes 1-4, 5-8, 9-12, and 13-16. The Unit Code Set is selected by removing or installing shorting blocks on the jumpers labeled 0 & 1. The table below shows how to set the proper Unit Code Set:

Unit Code Set	Jumper 1	Jumper 0
1 – 4	Shorting Block INSTALLED	Shorting Block INSTALLED
5 – 8	Shorting Block INSTALLED	Shorting Block Removed
9 – 12	Shorting Block Removed	Shorting Block INSTALLED
13 – 16	Shorting Block Removed	Shorting Block Removed

8-Relay boards can be set to Unit Codes 1-8 and 9-16. The Unit Code Set is selected using the Jumper labeled U. To select Unit Codes 1-8, install the shorting block on Jumper U. To select Unit Codes 9-16, remove the shorting block from jumper position U.

All board versions can be set to momentary mode. Normally, when an ON command is received, the associated relay is turned ON and it stays ON until an OFF command is received for the given Unit Code. If you install a shorting block on the jumper labeled M, the board will be set to momentary mode.

In momentary mode, relays are turned on for approximately 1 second when an ON command is received and the relay then turns OFF. X10 OFF commands have no effect. If you hold the On button down on your X10 controller, the associated relay will stay on until 1 second after you release the button.

The 8 & 16 Relay Boards have a jumper labeled F. This jumper is used to enable or disable the All Off feature on 8 & 16 relay boards. If the F jumper is **removed**, the board

will turn all relays off when an All Off X10 code is received for the given house code. If the jumper is installed, the All Off command is ignored when received.

The X-10 Relay Boards support grouped X-10 commands. You can send multiple House/Unit Code commands followed by a single ON or OFF command and all relays will respond. This helps reduce HA controller program complexity as well as X-10 traffic in your home.

NOTE! Jumper settings only take effect when power is first applied. If you change any jumper settings, you must reset the X10 Relay Board by disconnecting and reconnecting the power cord.

X10 Processor Pinouts

Below are the pinouts for the 4, 8, and 16 relay processor chips:

4-Relay Processor

Pin 1 Relay Data
 Pin 2 Relay Clock
 Pin 3 /Momentary Cfg
 Pin 4 /RESET
 Pin 5 Vss
 Pin 6 X10 Zero Cross In
 Pin 7 X10 Tx
 Pin 8 X10 Rx
 Pin 9 Relay Latch Strobe
 Pin 10 House Code Bit 0
 Pin 11 House Code Bit 1
 Pin 12 House Code Bit 2
 Pin 13 House Code Bit 3
 Pin 14 Vdd
 Pin 15 OSC2
 Pin 16 OSC1
 Pin 17 Unit Code Bit 0
 Pin 18 Unit Code Bit 1

8-Relay Processor

Pin 1 Relay Data
 Pin 2 Relay Clock
 Pin 3 /Momentary Cfg
 Pin 4 /RESET
 Pin 5 Vss
 Pin 6 X10 Zero Cross
 Pin 7 X10 Tx
 Pin 8 X10 Rx
 Pin 9 Relay Latch Strobe
 Pin 10 House Code Bit 0
 Pin 11 House Code Bit 1
 Pin 12 House Code Bit 2
 Pin 13 House Code Bit 3
 Pin 14 Vdd
 Pin 15 OSC2
 Pin 16 OSC1
 Pin 17 Unit Code Select
 Pin 18 /All Off Disable

16-Relay Processor

Pin 1 Relay Data
 Pin 2 Relay Clock
 Pin 3 /Momentary Cfg
 Pin 4 /RESET
 Pin 5 Vss
 Pin 6 X10 Zero Cross
 Pin 7 X10 Tx
 Pin 8 X10 Rx
 Pin 9 Relay Latch Strobe
 Pin 10 House Code Bit 0
 Pin 11 House Code Bit 1
 Pin 12 House Code Bit 2
 Pin 13 House Code Bit 3
 Pin 14 Vdd
 Pin 15 OSC2
 Pin 16 OSC1
 Pin 17 Relay Data #2
 Pin 18 /All Off Disable

Any change to the configuration pins via jumpers will not take effect until the processor is RESET.

The X10 Relay Processors CANNOT drive relays on their own. This will burn out the processor. Appropriate relay drivers must be used, like the UCN5841 IC included with each kit.

X10 Relay Troubleshooting

- **The LED resistors seem to be very hot**

Unregulated 12VDC power supplies often produce more than 12VDC to ensure they still output 12VDC at their rated current load. Some of these supplies can put out > 18VDC! The LED current limiting resistors are designed to handle power supply voltages up to ~17VDC. Voltages above this will cause the resistors to get very hot as they exceed their ¼ Watt rating.

The power supplies shipped from CCC are regulated to put out 12VDC max. If you use a different power supply, make sure it is listed as 12VDC and puts out < 16.5VDC when disconnected from the board. Or get a regulated 12VDC power supply, which is better. We have found that unregulated 9VDC wall wart power supplies will generally put out 12VDC if they are rated for 1 Amp (4 & 8 relay boards) or 1.5 Amp (16 Relay boards).

X10 Relay Change History

v1.0

Original Release

v1.1

Removed Hail response. Only controllers should respond to Hail requests.
Removed 2-Way status query since the relay's cannot be manually turned on and most controllers monitor the lines for commands. This allows for a single chip to be used in 50Hz and 60Hz systems.

Need Help?



If you get stuck trying to get your X10 Relay system to work, drop us a line at support@cc-concepts.com and we will do our best to help you get your X10-Relay Board working.

Check out our web site at <http://www.cc-concepts.com/> for updates, bug reports, etc.

4 Relay X10 Interface
 (c)1998 Creative Control Concepts
<http://home.sprynet.com/sprynet/mbaptiste/ccs.html>

+12VDC
500mA

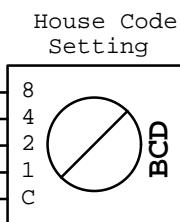
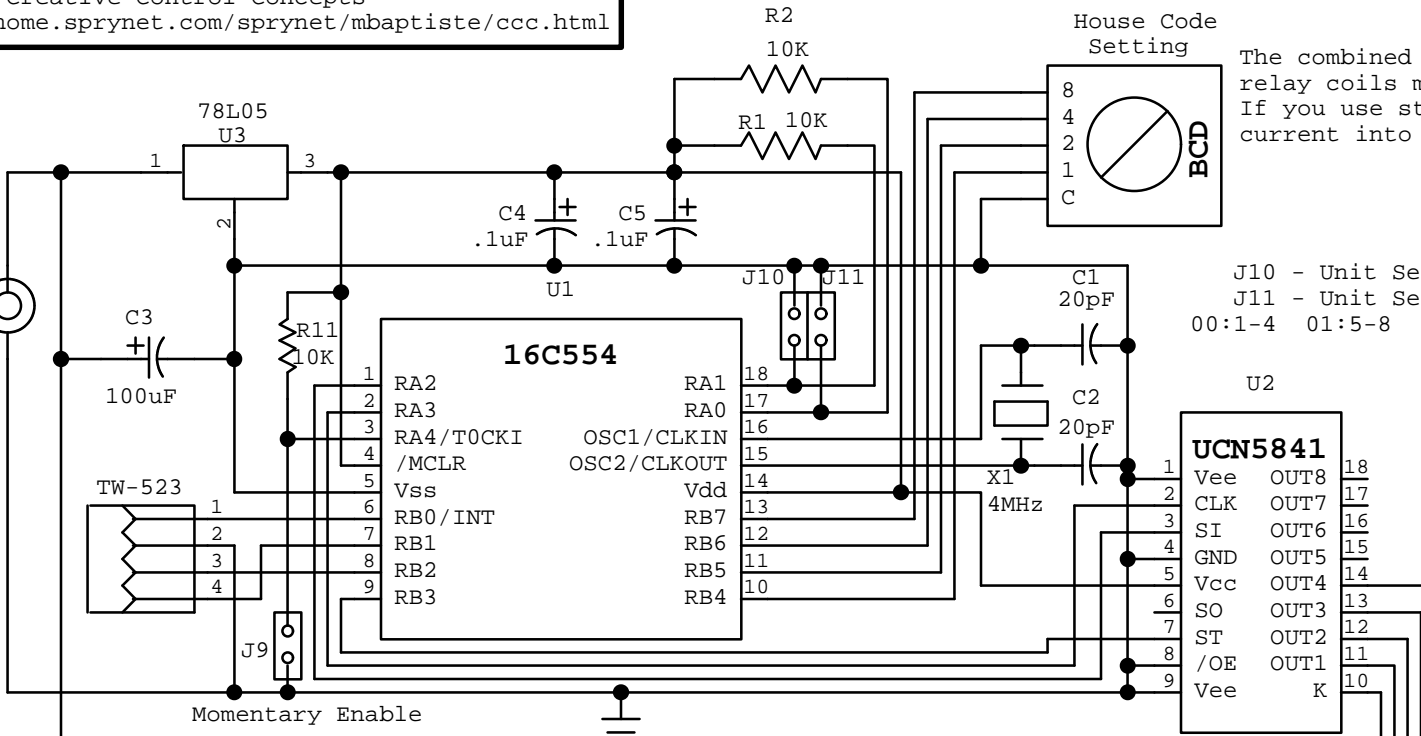

The combined current off all relay coils must NOT exceed 475mA! If you use status LEDs, take that current into account as well!

J10 - Unit Set Select Bit 1
 J11 - Unit Set Select Bit 0
 00:1-4 01:5-8 10:9-12 11:13-16

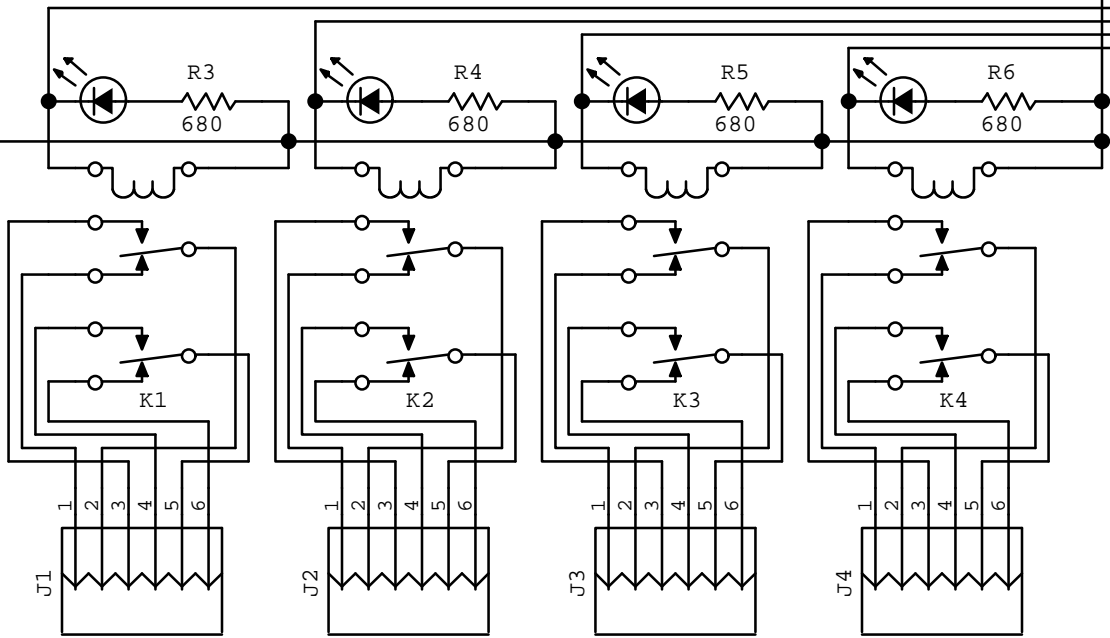

A B C D E

8 Relay X10 Interface
 (c)1998 Creative Control Concepts
<http://home.sprynet.com/sprynet/mbaptiste/ccs.html>

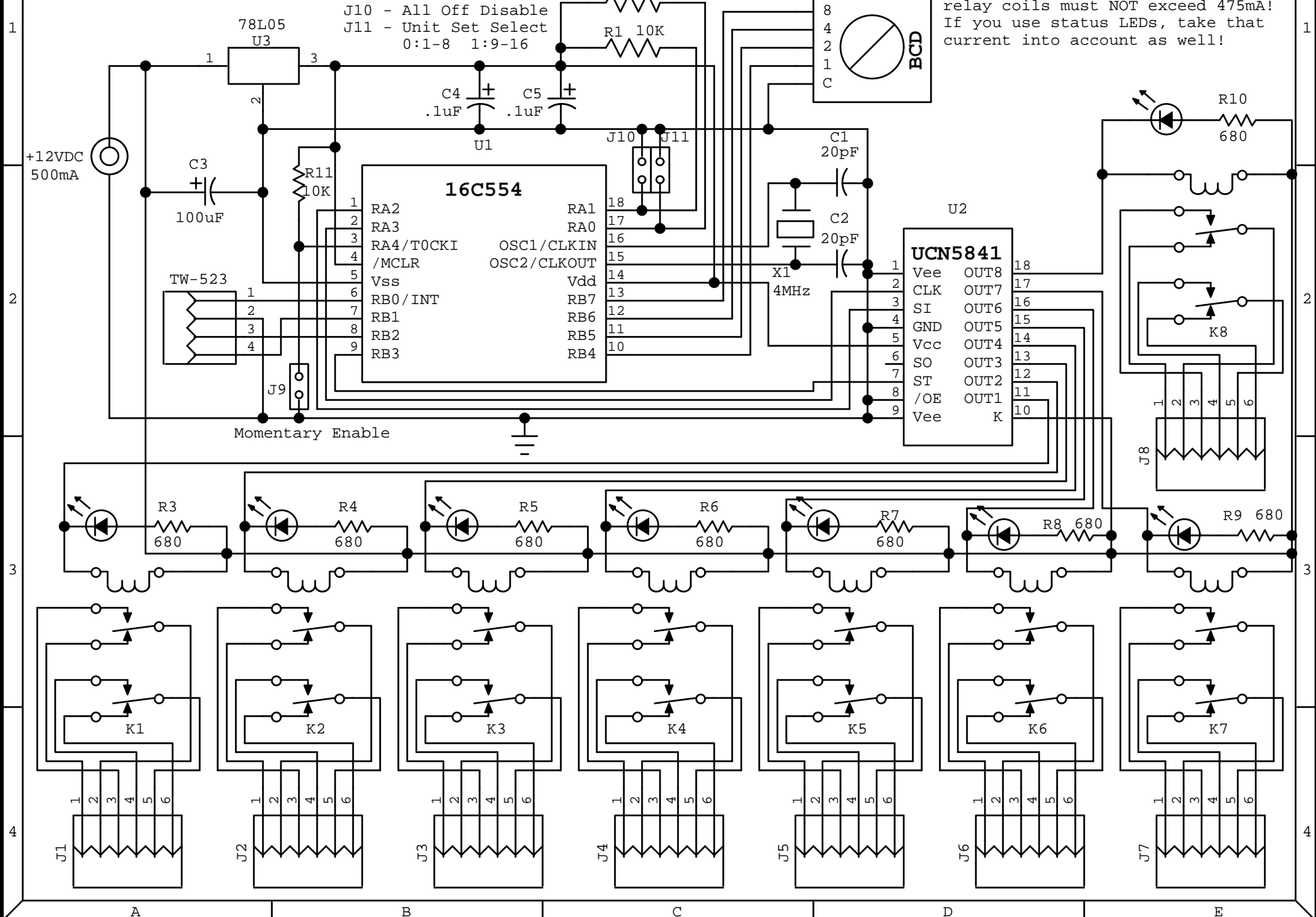

The combined current off all relay coils must NOT exceed 475mA! If you use status LEDs, take that current into account as well!

16-Relay X-10 Board
(c)2000 Creative Control Concepts
<http://www.cc-concepts.com/>
4/7/2000 - Rev A

Slave Board

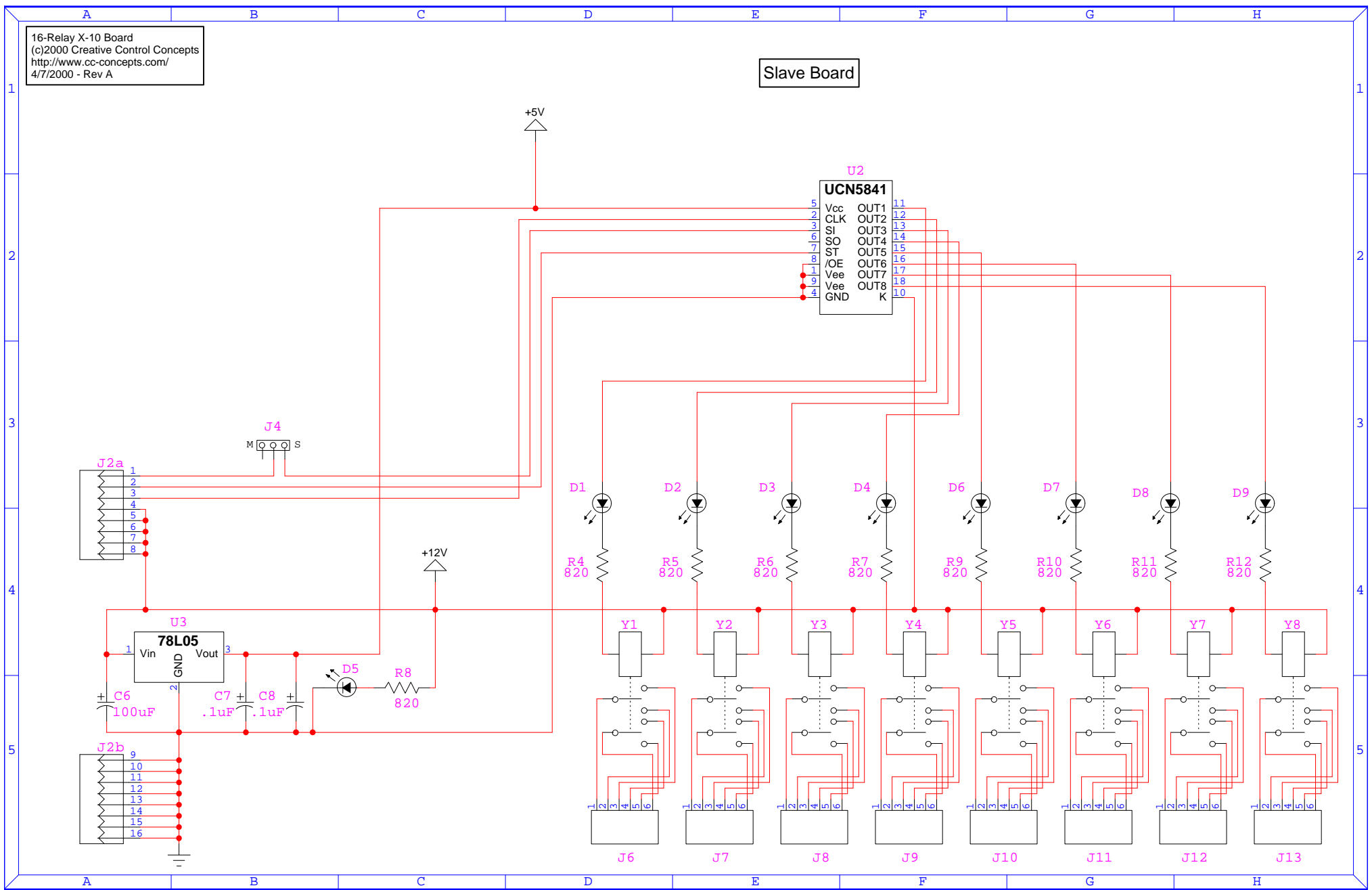

U2		
UCN5841		
5	Vcc	OUT1
2	CLK	OUT2
3	SI	OUT3
6	SO	OUT4
7	ST	OUT5
8	/OE	OUT6
1	Vee	OUT7
9	Vee	OUT8
4	GND	K

U3		
78L05		
1	Vin	Vout
2	GND	

- D1
- D2
- D3
- D4
- D6
- D7
- D8
- D9
- R4 820
- R5 820
- R6 820
- R7 820
- R9 820
- R10 820
- R11 820
- R12 820
- Y1
- Y2
- Y3
- Y4
- Y5
- Y6
- Y7
- Y8

- J6
- J7
- J8
- J9
- J10
- J11
- J12
- J13

